



RS-AE SERIES

MULTI CHANNEL AMPLIFIER

**Please carefully read the user manual.
Do not use your device without reading.**

Dear Customer,

First of all, we would like to thank you for choosing our REISS AUDIO branded device, which is the pioneer of quality.

In order for your device, which has been produced in modern facilities and has undergone rigorous quality control, to offer you the best efficiency,

Please read this entire manual carefully before using your device and keep it as a reference.

RULES TO BE FOLLOWED IN MAINTENANCE, REPAIR AND USE

ONLY AUTHORIZED TECHNICAL PERSONS CAN OPEN THE BACK COVER.
THE WARRANTY OF THE DEVICE IS APPLICABLE TO DEVICES WITHOUT OPEN BACK COVER.
TO AVOID FIRE HAZARD AND DANGEROUS SHOCK, DO NOT EXPOSE THE APPLIANCE TO MOISTURE OR RAIN.
DO NOT WIPE WITH A DAMP CLOTH WHILE THE DEVICE IS WORKING.

Wipe the device with a soft cloth.

Do not wipe the device with alcohol, gasoline or chemical cleaning agents.

MATTERS TO BE CONSIDERED DURING HANDLING AND SHIPPING

The device must be transported in its original packaging.
It should not be dropped, it should be kept away from water and excessively humid environment.
SITUATIONS THAT MAY BE HARMFUL TO HUMAN AND ENVIRONMENTAL HEALTH DURING USE
RISK OF ELECTRIC SHOCK INSIDE THE DEVICE, WHICH MAY BE DANGEROUS TO PEOPLE
'DANGEROUS VOLTAGE MAY BE AVAILABLE.
NEVER OPEN THE BACK COVER. OTHERWISE, THIS SITUATION CAN BE DANGEROUS TO PEOPLE AND
MAY CAUSE SERIOUS PROBLEMS IN THE OPERATION OF THE DEVICE

Feature Set of the AE Series Multi-Channel Amplifiers

- Heavy Density Aluminum Extruded Heatsink
- 4 Layer PCB, SMD Technology
- Conformal Coated PCB
- Output Clipping Indicators
- Fully Variable Crossover 24dB / Octave Slope
 - 48dB / Octave on Subchannel of AE1800.5D
- Dual Boost Circuitry Active in both HP and LP Modes
- Input Mode Selector (2Ch. or 4Ch.) AE1000.4D and AE1800.4D
 - Input Model Selector (2Ch. or 5Ch.) AE1800.5D
 - Input Mode Selector (2Ch. or 6Ch.) AE1200.6D
- Selectable Input Voltage
 - High Level Input / Speaker Level Input
 - Low Level Input / RCA Input
 - Remote Input Becomes Remote Output Trigger if High level Input is used.
- Selectable Turn-On Modes
 - Remote, Signal Sensing, DC Offset
- Power and Protection Logo Illuminated Status Indicator
 - Blue Indicates Amplifier is powered On
 - Red Indicates the Amplifier is in Protection
- Gold Plated Differential Balanced Tiffany RCA
- Gold Plated 4 Gauge Power & Ground Terminals
 - Gold Plated 1/0 Power & Ground Terminals (AE1800.4D & AE1800.5D)
- Gold Plated 8 Gauge Speaker Output Terminals
- Advance Protection Circuit Monitoring: Short, Thermal, Overload and Impedance
- Finish: Anodized with Texture Paint

What's Included

- (1) AE Series Channel Amplifier
- (6) Self Tapping Screws; (4) for Amplifier, (2) for Remote
- (2) Allen Wrenches
- (1) Remote Level Controller
- (1) Instruction Manual
- (1) Sticker

Important Safety Considerations

- To prevent personal injury and damage to the unit, please read the follow the instructions in this manual.
- This product is designed to use in vehicles with 12Volt, negative-ground electrical systems.
- Install this product in a dry location away from your vehicles' safety equipment (airbags, seat belt system, etc.). Water and humidity may damage internal components.
- Use the included mounting accessories to secure this product so that it does not come loose.
- Check before drilling to make sure you do not drill into any vital vehicle system.
- Protect all system wiring from sharp metal edges.
- Do not disassemble or modify this unit; doing so will void your manufacturer's warranty.

Important Installation Precautions

Installation of mobile audio equipment requires experience. Although this manual provides general installation procedures, it will not show the exact installation method for your particular vehicle.

If you do not have the required knowledge and experience, we recommend that you have your equipment installed by an Authorized ReissAudio Dealer.

- Turn off all stereo and other electrical devices before you begin.
- Disconnect the negative (-) lead from your vehicle's battery to avoid an electrical short. Reconnect the negative lead to your battery once your installation is complete. So, in other words the negative lead from our vehicle's battery is the first connection you remove before starting your installation and the last connect your make after you finish your installation.
- Check your mounting location to make sure there is sufficient room for your installation placement preference.



Important Installation Precautions Continued

- Install this product in a dry location away from your vehicles' safety equipment. Each AE Series amplifier circuit board has been coated with a protective layer of Conformal Coating. This will help protect the electronic circuit from harsh environments that may contain humidity and a range of airborne contaminants and varying temperatures. However prolonged exposure to water and high humidity may damage internal components in time so keeping the amplifier dry and installed in a well-ventilated area will help ensure many years of listening enjoyment.
- When running power cables through sheet metal it is best to use grommets and loom to properly insulate your cables from metal edges.
- Avoid mounting the amplifier with the top fins facing down as this may increase the operating temperature of your amplifier.
- If mounting underneath a seat, make sure that there is at least 1 inch (25mm) of space above the amplifier to permit proper cooling.
- Avoid mounting the amplifiers on a subwoofer enclosure as prolonged excessive vibration may damage your amplifier.

Mounting Placement

Choose a structurally sound location to mount your ReissAudio amplifier, making sure there are no items behind the area where the screws will be driven.

For optimum sound quality, it is highly recommended that you purchase ReissAudio wiring accessories as they are designed to give your amplifiers high-quality signal it needs to operate at peak performance levels. ReissAudio provides a wide selection from RCA cables and power wire to speaker wire and battery connectors.

Side Panel Layout

AE1000.4D & AE1800.4D

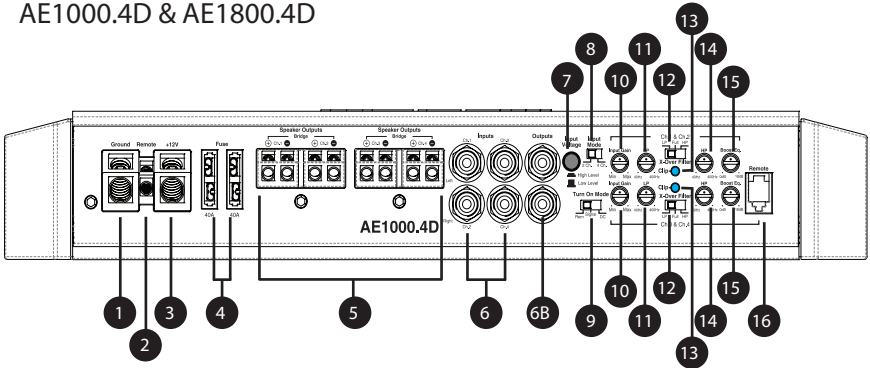

AE1200.6D

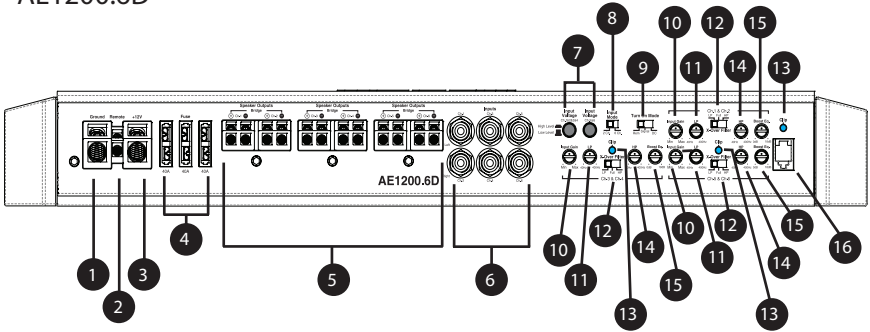

AE1800.5D

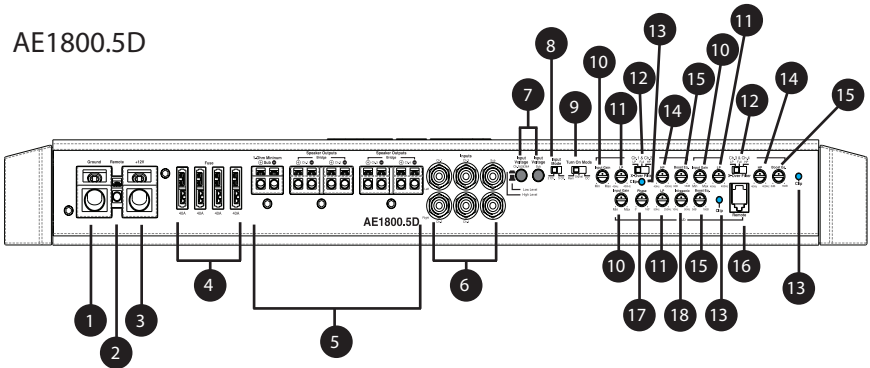

Side Panel Layout Continued

1. Ground: The Ground terminal is designed to accept up to 4 Gauge AWG wire on the AE1000.4D and AE1200.6D and up to 1/0 Gauge AWG wire on the AE1800.4D and the AE1800.5D. Make your ground connection directly to the chassis of the vehicle as close to the amplifier as possible. Make sure this connection is made with the same gauge wire as used for your +12Volt connection. Ensure that all dirt, grease and paint is removed from your chassis ground point prior to attaching the ground wire. **ReissAudio** recommends when making your chassis ground to use a Star Washer which will help prevent your ground bolt from loosening. Turn the set screws on this terminal counterclockwise to loosen the screw using the supplied Hex wrench. Strip the PVC jacket from your ground wire ½ inch (12mm). Then insert the bare wire into the terminal block so that no bare ground wire is exposed. Then tighten the set screw by turning it clockwise.
2. Remote Input Terminal: This terminal must be connected to a switched +12Volt source. If the source unit does not have a remote Turn on lead, then a switched +12Volt supply should be used such as the ACC +12Volt. Run an 18-gauge wire from the Remote Turn-On Lead from your headunit / source unit to this terminal.
If you are using the High-Level Speaker Outputs connection **to the amplifiers' RCA inputs, you do not need to connect a remote input to your amplifier. Your amplifier will automatically detect the speaker signal and will turn on your amplifier via its DC Offset circuit. In addition, the remote input terminal then becomes a remote output trigger which can be used to turn on another amplifier or processor that requires a +12volt remote connection.**

Side Panel Layout Continued

3. **+12Volt Positive Terminal:** The +12Volt positive terminal is designed to accept up to 4 Gauge AWG wire on the AE1000.4D and AE1200.6D and up to 1/0 Gauge AWG wire on the AE1800.4D and the AE1800.5D. Make your +12Volt connection directly to the positive battery post. An external fuse use should be installed within 18" (457mm) of the battery. This fuse is vital to protecting the vehicle and amplifier from a dead short. Turn the set screw on this terminal counterclockwise to loosen the screw using the supplied Hex wrench. Strip the PVC jacket from your power wire ½ inch (12mm). Then insert the bare wire into the terminal block so that no bare power wire is exposed. Then tighten the set screw by turning it clockwise. For maximum current flow, ReissAudio recommends that you tin your power & ground wire before connecting it to the +12Volt terminal. In addition, ReissAudio recommends using high quality 100% OFC (Oxygen Free Cooper) or Tinned 100% OFC speaker wire. This will ensure that your speaker /subwoofer receives maximum output from your amplifier.

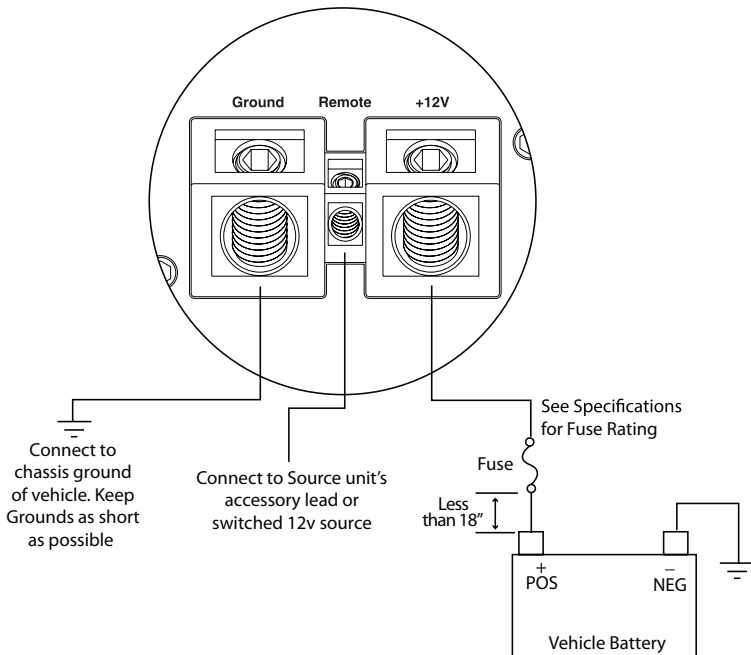

Side Panel Layout Continued

4. Fuse Holder: This is your amplifier's fuse block. Should there be a short in your system or if your amplifier is being over driven, these fuse(s) will typically burn to prevent damage to your amplifier. If it is required to replace your fuse(s), use the same fuse rating that comes with your amplifier. Using a higher fuse may damage your amplifier and will void your warranty.

5. Speaker Outputs: Your AE amplifier speaker outputs are designed to accept up to 8 Gauge AWG. Turn the set screws on this terminal counterclockwise to loosen the screws using the supplied Hex wrench. Strip the PVC jacket from your speaker wire ½ inch (12mm). Then insert the bare wire into the terminal block so that no bare speaker wire is exposed. Then tighten the set screw by turning it clockwise.

For maximum current flow, ReissAudio recommends that you tin your speaker wire before connecting it to the speaker output terminals. In addition, ReissAudio recommends using high quality 100% OFC (Oxygen Free Cooper) or Tinned 100% OFC speaker wire. This will ensure that your speaker / subwoofer receives maximum output from your amplifier. Visit [www. ReissAudio.com](http://www.ReissAudio.com) or talk to your Authorized **ReissAudio** Dealer to see a complete selection of premium installation accessory that will complement and enhance listening experience.

Loading your amplifier below the recommended impedance rating found on page 19 is not recommended and may cause your amplifier to enter into protection mode and may void your warranty.

6. Low Level RCA Inputs: These are your differential balanced inputs that are used to connect audio signal from your headunit / source unit to your amplifier. Your AE Series Amplifier is capable to receiving either High Level Speaker Outputs or Low-Level RCA cables. If you are using High Level Speaker outputs, you may need a high to low level adapter such as the ReissAudio AP-SL2 adapter.

6B. Low Level RCA Preouts (AE1000.4D & AE1800.4D Only): This pair of RCAs Preouts can be used to send audio signal from your amplifier to another amplifier without the need of using RCA Splitter Y-Cables.

Side Panel Layout Continued

7. **Input Voltage Selector:** Your AE Amplifier is designed to accept a wide range of input signal from 250mV to 10V RMS. This button allows you to select how your amplifier will receive its audio input signal. If you are using Low Level RCA's make sure the button is in the outward position. If you are using High level speaker outputs as your signal input, make sure this button is in the inward position. Incorrectly selecting the Input Voltage Selector will result in low or distorted output.
8. **Input Mode Selector:** This switch allows you to select the number of RCA inputs used to send audio signal to your amplifier. In 2 Channel Model, only 1 set of RCA inputs is needed to drive all output channels. (You will need to set the Input Mode switch to the 2Ch. position.) In 4 Channel Mode, all 4 RCA inputs will need to be connected, and the Input Mode switch will need to be set to the 4Ch. position (AE1000.4D and AE1800.4D). The AE1200.6D has a 2Ch. or 6Ch. option and the AE1800.5D has a 2Ch. or 5Ch. option. **If the 2Ch. position is selected, the only RCA inputs used will be Ch.1 and Ch.2 to drive all of the amplifier's outputs.**
9. **Turn On Mode Selector:** Your AE amplifier has 3 methods of turning on and turning off which is determined by the position of this Mode Selector.
 - a. **Remote (+12Volt Remote Turn-On Lead):** This is the most common method of turning the amplifier on/off. Your amplifier will turn on when there is a +12V present and will turn off when the +12V is switched off.
 - b. **Signal (Signal Sensing Circuit):** This is an alternative method of turning your amplifier on and off. If your source unit does not have a dedicated remote turn-on output, using the Signal Sensing Circuit, when your amplifier detects audio signal the amplifier will turn on. When no signal is detected the amplifier will shut off within 30 seconds. When using Signal Sensing, you will not need to wire a remote input to the amplifier. This circuit senses input from Channel 2. The sensitivity of this circuit varies slightly from different vehicles and different OEM (Factory) radios.



Side Panel Layout Continued

- c. **DC (DC Offset Circuit):** This is an alternative method of turning your amplifier on and off. If your source unit does not have a dedicated remote turn-on output, using the DC Offset Circuit will turn your amplifier on/off when it detects a very small amount of DC signal from the audio output of your source unit. The sensitivity of this circuit varies slightly from different vehicles and different OEM (Factory) radios. **When using DC Offset, you will not need to wire a remote input to the amplifier. This circuit senses input from Channel 1.**
10. **Input Gain:** Use these Input Gain Potentiometers to match the output voltage of your headunit / source unit to the input circuit of your amplifier. These Input Gains are not a volume knob. A simple method of setting your Input Gains is to turn your headunit / source unit up to approximately $\frac{3}{4}$ volume. Then slowly adjust your Input Gains on your amplifiers clockwise until you can hear distortion from your speakers or subwoofers. Then turn the gains down (counter clockwise) till the distortion is no longer heard and your clipping indicators are not fully lit.
11. **Low Pass (LP) Filter Frequency Filter:** This potentiometer is used when the amplifier is set to Low Pass Mode and allows you to adjust the crossover frequency from 40Hz – 400Hz. The Subwoofer channel on the AE1800.5D has a variable Low Pass Filter from 50Hz – 250Hz.
12. **Crossover Filter Selector (X-Over Filter)** : Depending on how you will use your AE Amplifier, you will select the appropriate setting on the Crossover switch. Set the Crossover Switch to LP (Low Pass) mode if you are using Subwoofers or MidBass drivers. Set the switch to HP (High Pass) if you want the amplifier's internal crossover to serve as a high pass filter. When the switch is set to the Full position, this will allow the amplifier to send its full bandwidth to your speakers. Avoid changing the crossover switches with the audio system playing at high volumes as this may damage your speakers.

Side Panel Layout Continued

13. **Clipping Led Indicators:** These LED's will light up when the amplifier output signal is being clipped. When the LED's starts to glow, your amplifier output is between 1-2% THD (Total Harmonic Distortion). When the clipping indicators are fully lit, your amplifier output is between 6-7% THD (Total Harmonic Distortion). The ideal gain setting is where the clip indicators are not lit allowing the amplifier to send undistorted clean output. Setting the amplifiers gains improperly where the clip indicators are always lit will over-work the amplifier and may cause excessive heat building and possibly product failure.
14. **High Pass Filter Frequency Filter:** This potentiometer is used when the amplifier is set to High Pass Mode and allows you to adjust the crossover frequency from 40Hz – 400Hz.
15. **Boost Eq:** Your AE Series amplifiers incorporate a two stage Boost Eq. circuit that is not only active in Low Pass Mode but is also active in High Pass Mode. In Low Pass Mode, the Boost Eq. can increase output 0-18dB centered at 45Hz. In High Pass Mode, the Boost Eq can increase output 0-18dB centered at 12kHz. Note if you turn up the Boost Eq, you will need to readjust the Input Gains to avoid clipping the output signal. Using the Clipping LED's will help set your Boost Eq and Input Gains properly.
16. **Remote Level Control:** With the Remote Level Control plugged to your amplifier, you can now adjust the amount of output from the convenience of this controller. There are several mounting options for your controller. With the supplied wing attachment, you can mount the controller under your dash. Should you want to mount the controller flush to your dash, arm rest or any other panel of your vehicle the wing attachment will more than likely not be needed.
 - a. AE1000.4D and AE1800.4D: The Remote Level Controller will adjust the output of Ch.3 and Ch.4. in all Crossover modes; HP (High Pass), LP (Low Pass) and Full.



Side Panel Layout Continued

- b. AE1200.6D: The Remote Level Controller will adjust the output of Ch.5 and Ch.6. in all Crossover modes; HP (High Pass), LP (Low Pass) and Full.
- c. AE1800.5D: The Remote Level Controller will adjust the output for the Subwoofer Channel.

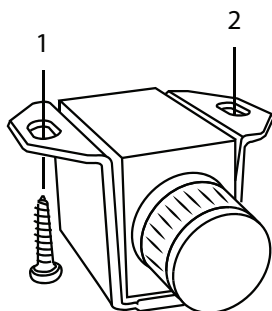

17. Phase Switch (AE1800.5D Only): Depending on the absolute phase of your main speakers and amplifier and the distances of the subwoofer and the main speaker from the main listening position, the bass in the crossover region maybe smoother if you reverse the subwoofer's phase. Try both settings to determine which polarity produces the best overall bass performance in your system. Typically, though, phase is left at the 0° for most installation.

Side Panel Layout Continued

18. Infrasonic Filter (AE1800.5D Only): This variable potentiometer will provide a roll off point for lower frequencies (10Hz – 50Hz variable) that could potentially damage your subwoofers from over-excursion. The frequency setting for your Infrasonic Filter is to be set relative to your speaker's low-frequency capabilities along with enclosure tuning. In a sealed box ReissAudio recommends setting the Infrasonic Filter between 25Hz – 35Hz. In a ported enclosure ReissAudio recommends setting the Infrasonic filter at $\frac{1}{2}$ an Octave below your tuned frequency.

For example, let say your ported enclosure is tuned at 40Hz. Take $\frac{1}{2}$ of 40Hz which is 20Hz (this is one octave lower). Now take another half off 20Hz which is then 10Hz (this is half an octave lower). Now take 10Hz from 40Hz which is 30Hz and where you should set your Infrasonic Filter.

Common Installation Diagrams

The illustrations below show the common installation methods for your amplifier. It is important to make sure that the impedance of your speakers connected to your amplifier is either 4-ohms Stereo, 2-ohm Stereo or 4-ohm bridged. (The Subwoofer Channel on the AE1800.5D is stable to 1-ohm mono.) Connecting your amplifier below these impedances are not recommended as they will cause your amplifier to go into protection. If you are unsure of the impedance, it is recommended that use a DMM (Digital Multi-Meter) to check the impedance of your connection at the amplifiers' Speaker Output Terminals. Your amplifier will need to be off in order to get accurate measurements.



Common Installation Diagrams Continued

AE1000.4D & AE1800.4D

4 - Channel Speaker Output Connection

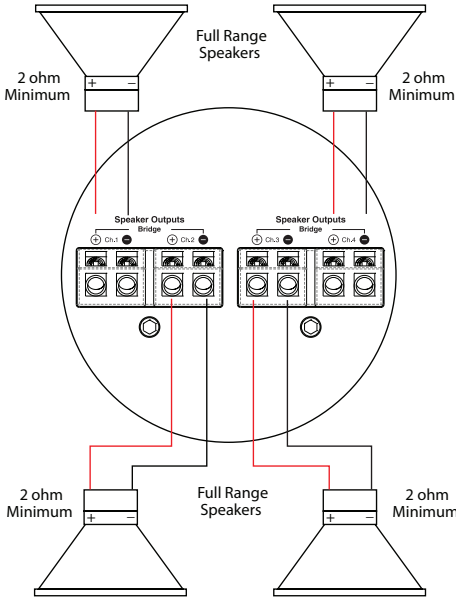

Side Panel Switch Position

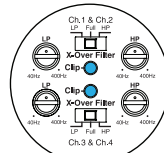

OR

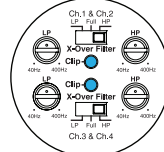

3 - Channel Stereo/Mono Speaker Output Connection

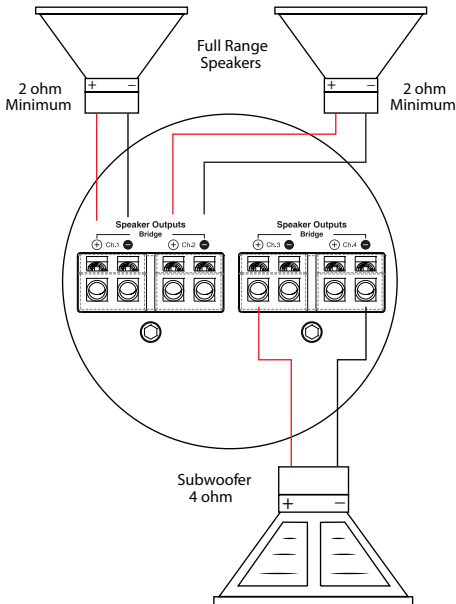

Side Panel Switch Position

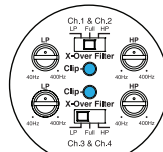

OR

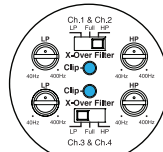

Common Installation Diagrams Continued

2 - Channel (Bridged Mode) Speaker Output Connection

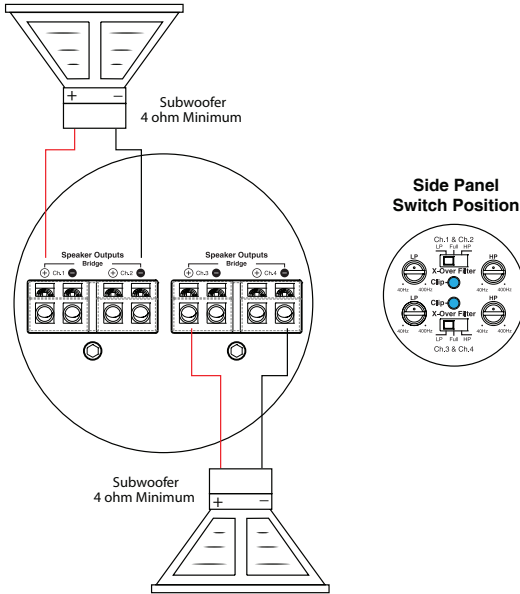

AE1200.6D

6 - Channel Speaker Output Connection

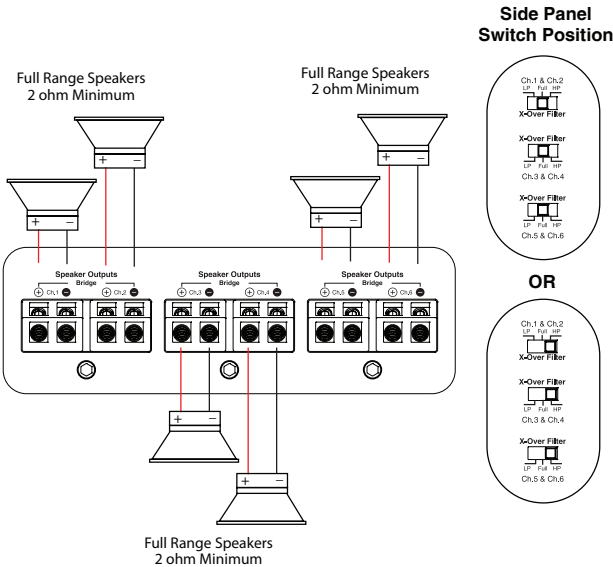

Common Installation Diagrams Continued

5 - Channel Stereo/Mono Speaker Output Connection

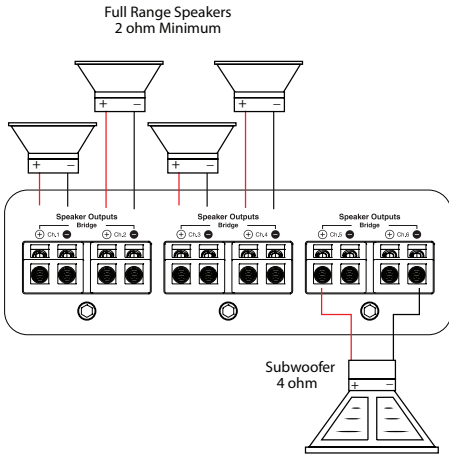

Side Panel Switch Position

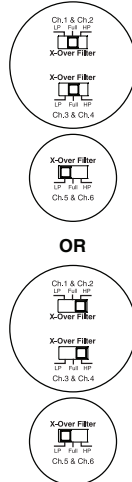

4 - Channel (Bridged Mode) Speaker Output Connection

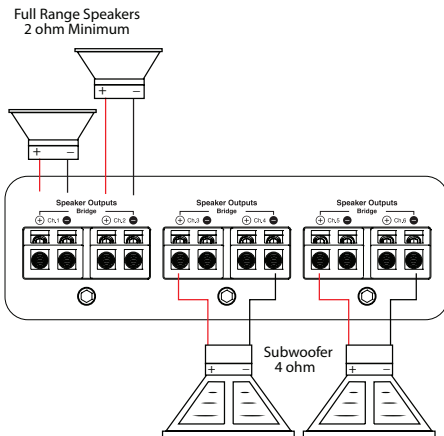

Side Panel Switch Position

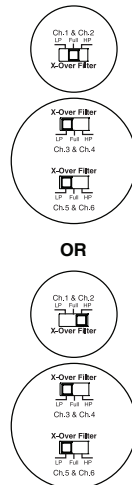

Common Installation Diagrams Continued

AE1800.5D

5 - Channel Speaker Output Connection

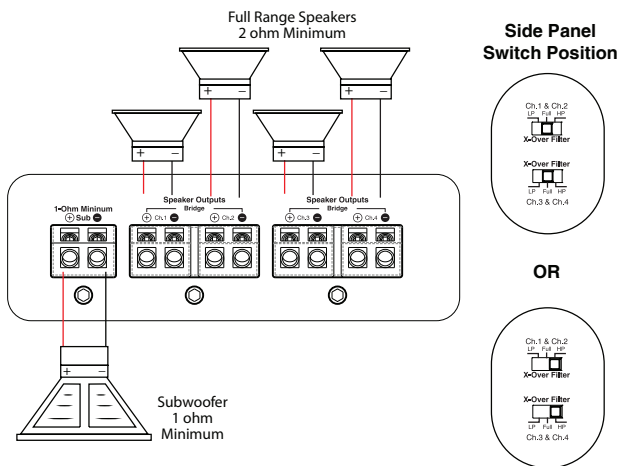

3 - Channel Stereo/Mono Speaker Output Connection

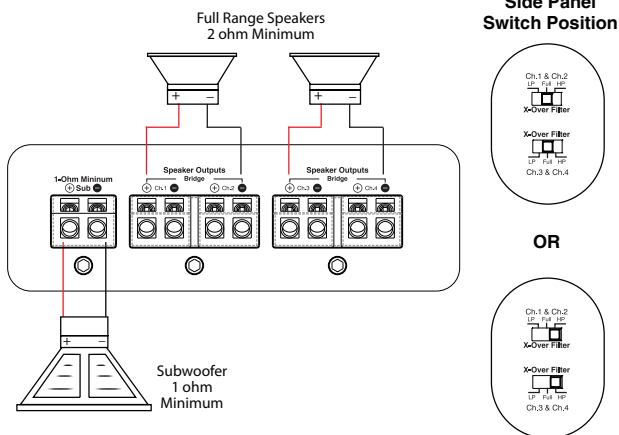



Note: One of the leading causes of amplifier failure is using inferior Power, Ground and Speaker wires that are not sufficient in quality to deliver the necessary current to keep your amplifier performing at its peak level. As all ReissAudio amplifiers are designed to deliver high power output, we recommend that you do not use any power wires that contains CCA (Copper Clad Aluminum). Instead we recommend only using high quality 100% OFC (Oxygen Free Copper) or 100% Tinned OFC (Oxygen Free Copper) wires. This will help give your amplifier the proper current and will ensure that your amplifier will perform at this peak perform level for many years to come.



Ask your Authorized ReissAudio Dealer or visit www.reissaudio.com.tr to view the complete line of installation accessory that will compliment your audio investment. ReissAudio provides a wide election from RCA cables and power wire to speaker wire and battery connectors.

Technical Specifications

Specifications	AE1000.4D	AE1800.4D	AE1200.6D
Channels	4	4	6
Rated RMS Power 4 Ohms Stereo @ 14.4 Volts	150 Watts x 4	300 Watts x 4	125 Watts x 6
Rated RMS Power 2 Ohms Stereo @ 14.4 Volts	250 Watts x 4	450 Watts x 4	200 Watts x 6
Rated RMS Power 4 Ohm Bridged @ 14.4 Volts	500 Watts x 2	900 Watts x 2	400 Watts x 3
Peak Music Power	2000 Watts	3600 Watts	2400 Watts
Frequency Response	10Hz – 40kHz	10Hz – 40kHz	10Hz – 40kHz
THD + Noise	< 0.5%	< 0.4%	< 0.6%
S/N Ratio A-Weighted	> 104dB	> 102dB	> 104dB
Input Sensitivity	250mV – 10V	250mV – 10V	250mV – 10V
Crossover High Pass (24dB/Octave)	40Hz – 400Hz	40Hz – 400Hz	40Hz – 400Hz
Boost EQ High Pass 0 - 18dB @ 12kHz Centered	0 – 18dB	0 – 18dB	0 – 18dB
Crossover Low Pass (24dB/Octave)	40Hz – 400Hz	40Hz – 400Hz	40Hz – 400Hz
Boost EQ Low Pass 0 - 18dB @ 45Hz Centered	0 – 18dB	0 – 18dB	0 – 18dB
Efficiency @ 4 Ohm	83%	83%	84%
Operating Voltage	9 – 17 Volts	9 – 17 Volts	9 – 17 Volts
Fuse Requirement	80A (Included)	160A (Included)	120A (Included)
Dimensions (H x W x D) Inches	2.2 x 13.5 x 7.5	2.2 x 15.4 x 7.5	2.2 x 17.4 x 7.5
Dimensions (H x W x D) MM	56 x 343 x 191	52 x 392 x 157	52 x 442 x 157

Specifications	AE1800.5D
Channels	5
Rated RMS Power 4 Ohms Stereo Ch.1 - Ch.4 @ 14.4 Volts	125 Watts x 4
Rated RMS Power 2 Ohms Stereo Ch.1 - Ch.4 @ 14.4 Volts	200 Watts x 4
Rated RMS Power 4 Ohm Bridged Ch.1 - Ch.4 @ 14.4 Volts	400 Watts x 2
Rated RMS Power 4 Ohm Mono Sub Ch. @ 14.4 Volts	350 Watts x 1
Rated RMS Power 2 Ohm Mono Sub Ch. @ 14.4 Volts	600 Watts x 1
Rated RMS Power 1 Ohm Mono Sub Ch. @ 14.4 Volts	1000 Watts x 1
Peak Music Power	3600 Watts
Frequency Response	10Hz – 40kHz
THD + Noise	< 0.6%
S/N Ratio A-Weighted	> 101dB
Input Sensitivity (Auto Detect High / Low Level)	250mV – 10V
Crossover High Pass (Ch1 - Ch.4) @ 24dB/Octave	40Hz – 400Hz
Boost EQ High Pass (Ch1 - Ch.4) - 12kHz Centered	0 – 18dB
Crossover Low Pass (Ch1 - Ch.4) @ 12dB/Octave	40Hz – 400Hz
Boost EQ Low Pass (Ch1 - Ch.4) - 45Hz Centered	0 – 18dB
Crossover Low Pass (Sub Ch.) @ 48dB/Octave	50Hz – 250Hz
Boost EQ (Sub Ch.) - 45Hz Centered	0 – 18dB
Infrasonic Filter	10Hz - 50Hz
Efficiency @ 4 Ohm	82%
Operating Voltage	9 – 17 Volts
Fuse Requirement	160A (Included)
Dimensions (H x W x D) Inches	2.2 x 19.0 x 7.5
Dimensions (H x W x D) MM	56 x 482 x 191

***This manual is the exclusive property of ReissAudio, Inc. Any reproduction of this manual or use other than its intended purposes is strictly prohibited without the express written consent of ReissAudio, Inc. ©Copyright 2020 ReissAudio, Inc.**



Troubleshooting

Problem	Solution
Amplifier does not work; no LED's on	1. Check to see if Power, Remote and Ground is connected to the Amplifier.
	2. Check Power and Remote Turn-on lead for proper +12 Voltage. (12 - 16 Volts DC acceptable range.)
	3. Check the inline fuse, replace if necessary.
Amplifier powers up; no sound	1. Check your RCA connectors to see if there is signal with a DMM (Digital Multi-Meter) to measure AC voltage.
	2. Check your speakers to see if there is short.
Hissing / Engine noise from speakers	1. Readjust your amplifiers gains to lower setting.
	2. Readjust your source unit volume.
	3. Make sure your RCA's and Speaker wires are routed away from your Power and Ground connections.
	4. Remove existing ground wires for all electrical components. Reground wires to a different location. Verify the grounding location is clean, paint from ground point has been removed and is rust free.
	5. Add a secondary ground cable from the negative battery terminal to the chassis metal or engine block of vehicle.
	6. Check your RCA cables or speaker input for any damage.
Distorted sound from speakers	1. Readjust your amplifiers gains to a lower setting.
	2. Readjust your source unit volume.
	3. Readjust the Boost Eq.
Logo Status LED is Red / Protection Circuit Active	1. Amplifier may be in thermal protection due to heat.
	2. Check the inline fuse, replace if necessary.
	3. Check the voltage at the amplifier power input terminals.